

MANUAL FOR INSTALLATION

M20i-CS • M40i-CS • M80i-CS

Version 2.0 - May 2011

This manual should be read carefully before the installation commences!

<i>How to assemble the plant</i>	page 1
<i>Connection to the heating system</i>	page 2
<i>Connection of the auger from extern fuel silo</i>	page 3
<i>Connection of the sprinkler</i>	page 3
<i>Connection of the safety heat exchanger</i>	page 4
<i>(Only for boilers provided with safety heat exchanger)</i>	
<i>Connection to the chimney</i>	page 4
<i>Connection to the electrical net</i>	page 5
<i>Diagram 1 – How to fit the water cooled burner tube, (side)</i>	page 6
<i>Diagram 1.1 – How to fit the water cooled burner tube, (rear)</i>	page 7
<i>Diagram 2 – Connection to the heating system</i>	page 8
<i>Diagram 3 – Connection of auger from extern fuel silo</i>	page 9
<i>Diagram 4 – Connection to the chimney</i>	page 10
<i>Diagram 5 – Electrical diagram 400V – 3 phase</i>	page 11
<i>Diagram 5.1 – Electrical diagram 230V – 1 phase</i>	page 12

Starting up the boiler – See users manual section 2



The installation of this plant must be made in accordance with the local rules and regulations on the place of installation

Before the plant is placed on its final place it should be inspected carefully for transport damages. Possible damages should be reported to the forwarder.

How to assemble the plant

The plant is delivered on 2 Euro pallets and consists of a boiler, a stoker and a burner tube which must be assembled before installation.

1. The water cooled burner tube is fixed on the stoker unit by means of bolts included. The gasket plus bolts for the fixation are included.
2. The stoker unit with the now fitted burner tube is pushed into the pre made hole with flange in the boiler.
3. Before you fixate the stoker and burner tube to the boiler (with 2 bolts) you must adjust the height of the stoker by means of 2 adjustment screws on the leg, that it is placed horizontal and in a 90° angle to the boiler. It is absolutely important, that the water cooled burner tube is horizontal as you otherwise might experience air pockets in the system.
4. The water cooling of the burner tube can now be installed as shown on **diagram 1 and diagram 1.1** All parts included fittings and circulation pump are in the accessories box included. (*Please note, that the circulation pump is for circulation between boiler and burner tube only*)
5. The combustion fan is fitted on the square stud of the burner tube, no gasket needed.
6. The hose for pressure equalising in the stoker is fitted on the stud on the burner tube
7. The draft regulator, needed by manual heating, is fixed on the top of the boiler in the same side as the door hinges for the combustion room door. The chain is connected to the lower air inlet on the boiler.
8. The plug for power to the boiler is pushed in and secured by a screw. The cable is placed in the tray underneath the plug. Cable W7 is for circulation pump.

The sketch indicates the recommended minimum distances in the boiler room. According to Danish fire rules the room must be equipped with a ½ to ¾ inch high pressure water tap and a ventilation opening, either as a window or as a ventilation grill

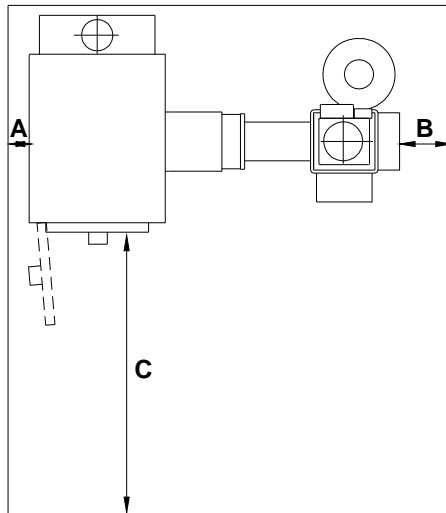

Recommended minimum distances in the boiler room (the stoker is placed at the right ore left side of the boiler)

Measures in cm

	A	B	C
M20i-CS	7	20	120
M40i-CS	10	20	160
M80i-CS	10	20	160

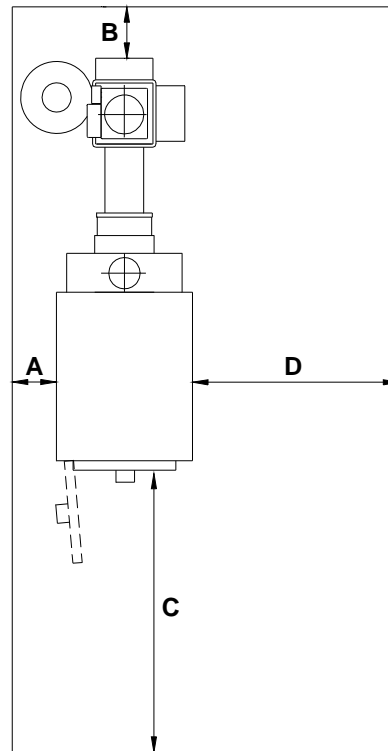

Recommended minimum distances in the boiler room (the stoker is placed at the rear side of the boiler)

Measures in cm

	A	B	C	D
M20i-CS	12	20	120	80
M40i-CS	12	20	160	80
M80i-CS	10	20	160	80

Connection to the heating system

See diagram 2

The boiler must be connected as shown in diagram 2 or as demanded by local statutes.

Further information is in the users manual, section. 7

The minimum amount of water passing through the boiler must be (see table)

Plant type	Nom. effect [kW]	Min. Amount of water [m ³ /h]
M20i	29	2,5
M40i	48	4,1
M80i	80	6,9

Water returning to the boiler must always be **min. 60°C**

If the above is not adhered to you will risk increased tear of the steel in the boiler, resulting in a shorter life expectation for the plant.

According to Danish laws and regulations this boiler must be connected to a system with “open” expansion tank. Please check you local regulations

General

The expansion tank must be able to contain at least 4 % of the total amount of water in the heating system. Should the plant be installed with an accumulation tank, then the expansion tank must be able to contain at least 8 % of the total amount of water in the heating system.

The boiler must be in non blockage connection to the expansion tank (You must not be able to block the pipe between)

Should the open expansion tank be placed in a not frost safe place, the tank itself must be protected against frost. The circulation to the tank may be controlled by a thermostatic valve or similar in order to secure, that the boiler water is getting minimum access to oxygen.

Connection of auger from extern fuel silo

See diagram no 3

The auger must give a certain amount, compared to the boiler type. See table below. If you try to enter an amount which lies outside the area listed in the table, the control unit will write “Error in weight”. It is described in section 2 in the Users guide how to weigh the fuel amount and key it into the control unit.

Permissible fuel amount for auger

Boiler type	Auger Kg/min
M20i-CS	0,8 – 11,5
M40i-CS	1,4 - 19
M80i-CS	2,2 - 32

The connection must be made with a flexible hose. The auger must not support on the stoker unit and vibrations from the auger must not be transmitted to the stoker unit.

In case the plant is connected to a silo placed at the loft above you should also use a flexible hose, which must be emptied after each filling. The hole through the ceiling must be made fire-proof.

Connection of the sprinkler

The sprinkler system for the boiler must be under constant water pressure from a ½ inch tap with a safety faucet and be connected to the dirt collector under the pressure tank.

Please make sure, that pipes / hoses are free of dirt or metal shavings.

You must test the system, when it has come under pressure.

The easiest way to test the sprinkler system is to unscrew the hose from the thermostatic valve to the auger channel. Then press the red cap under the valve to activate it

After testing the sprinkler system it is important to check that the valve is closing properly! (Dirt ore the like, in the valve seat, can prevent this)

Connection of the safety heat exchanger (Quenching coil)

(only for boilers provided with safety heat exchanger)

The boiler has a build-in safety heat exchanger which cools the boiler in case of pump failure or the like. The system will be activated if the water temperature in the boiler exceeds 95°C.

The thermal safety valve must be connected to constant water pressure from a G^{3/4}"/22mm pipe. The water pressure must be minimum 2 bar and the temperature maximum 15°C. There must be no shutoff valves on the pipe supplying the valve.

Flush the pipes before connecting to the thermal safety valve. Dirt or metal shavings can cause the valve to malfunction.

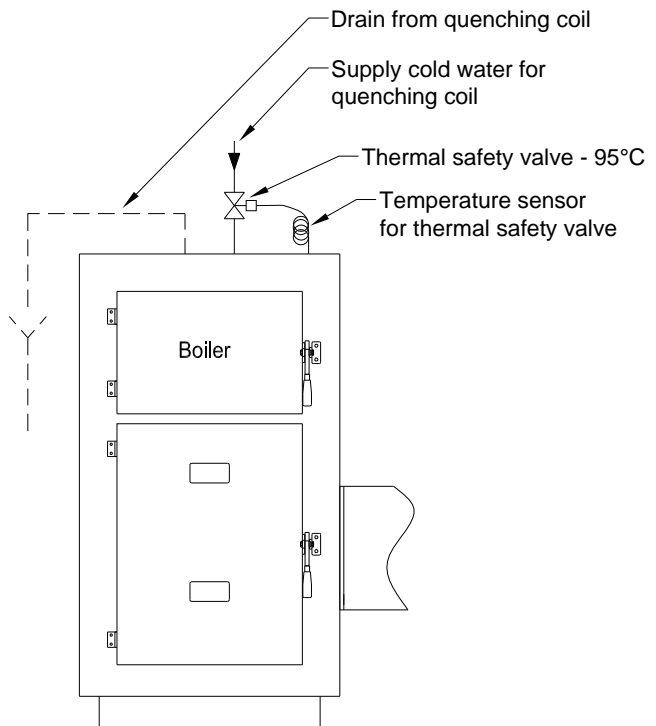

The return drain from the safety heat exchanger G^{3/4}" must be connected to a drain. The pipe used to connect to the drain must have a sufficient size to avoid the emergence of backpressure.

After installation the system must be tested to ensure free passage through the safety heat exchanger. The thermal safety valve can be manually activated by pressing the red cap.

Connection to the chimney

See diagram 4

Further information is in the users manual, section. 7

In order to get a good heating economy and to avoid smoke problems you must connect the boiler to a suitable chimney. The boiler should be placed as close to the chimney as possible.

Should the chimney be too unsuitable or under difficult draft conditions you might have to install a flue fan.

It is in general recommended to install a draft stabilizer (See diagram 4)
A chimney with unstable draft can cause unstable running conditions of the plant.

It is important that the flue pipe is insulated with a 30mm fire resistant mat, to avoid that the flue gasses are condensing in it.

Recommended chimney dimensions.

Plant type	Max. effect, input	Flue outlet on boiler	Free opening in chimney	Height of chimney
M20i	34 kW.	Ø 155 mm	Ø 160-180 mm	5-6 metre
M40i	55 kW.	Ø 187 mm	Ø 180-200 mm	5-8 metre
M80i	92 kW.	Ø 215 mm	Ø 200-250 mm	6-8 metre

Connection to the electrical net

See diagram no 5 / 5.1

The boiler can be built for both 400V 3 phase and 230V single phase connection.

Check boiler data plate for electrical connection.

In Denmark the installation must be made by an authorised electrician. Here too we ask you to check your local regulations

Electrical supply for the stoker plant:

There should be specific switch for this plant only

Electrical supply for the internal circulation pump:

The internal circulation pump (placed under the burner tube) is connected to cable W7.

The pump must not be started before filled with water, as this might damage it.

Setting of the internal circulation pump:

The pump must be set to run in a fixed step. It must not run in Auto mode!

Boiler	Pump step
M20i	I
M40i	I
M80i	II

The connection of start – stop signal for auger from extern silo:

See diagram no 5

The motor protection relay (contact) for the external auger must be supplied with a 230V start – stop signal from the controlling unit of the plant.

Diagram 1 - How to fit the water cooled burner tube by plants with stoker placed at the side of the boiler

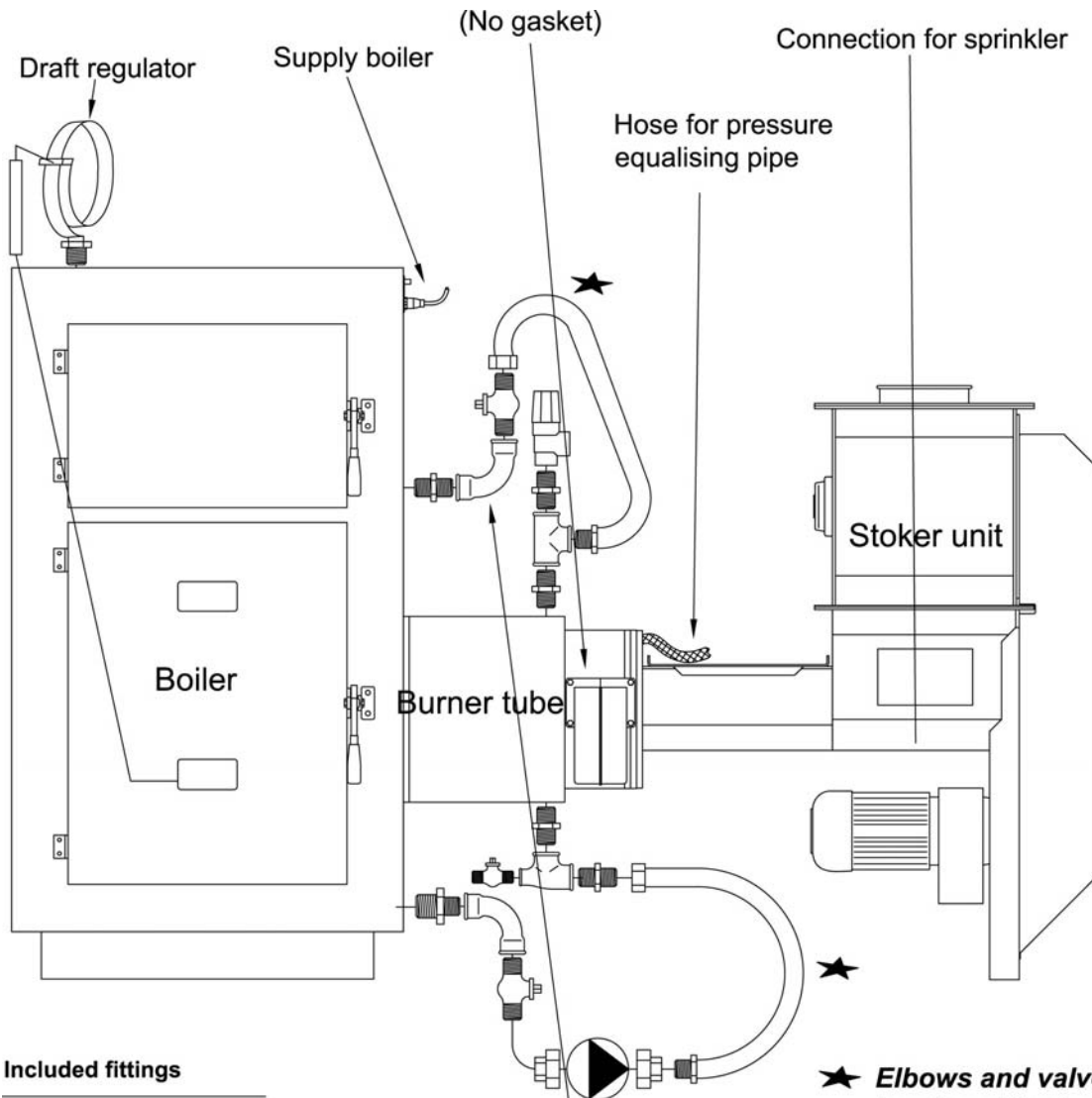

Included fittings

- 2 pcs. 3/4" Hose
- 1 pcs. 3/4" Safety valve
- 2 pcs. 3/4" Shutoff valve
- 1 pcs. 1/2" Shutoff valve
- 1 pcs. Circulation pump
- 5 pcs 3/4" Hexagon nipple
- 1 pcs. 3/4"x 3/4"x 1/2" Tee
- 1 pcs. 1"x 3/4" Hexagon nipple
- 1 pcs. 3/4" Tee
- 2 pcs. 3/4" Elbow
- 2 pcs. 3/4" Union joint, for pump

★ **Elbows and valves are to be placed horizontal, to avoid airpockets in the hoses!**

By M40 is included a 3/4" connection sleeve !

Diagram 1.1 - How to fit the water cooled burner tube by plants with stoker placed at the rear end of the boiler

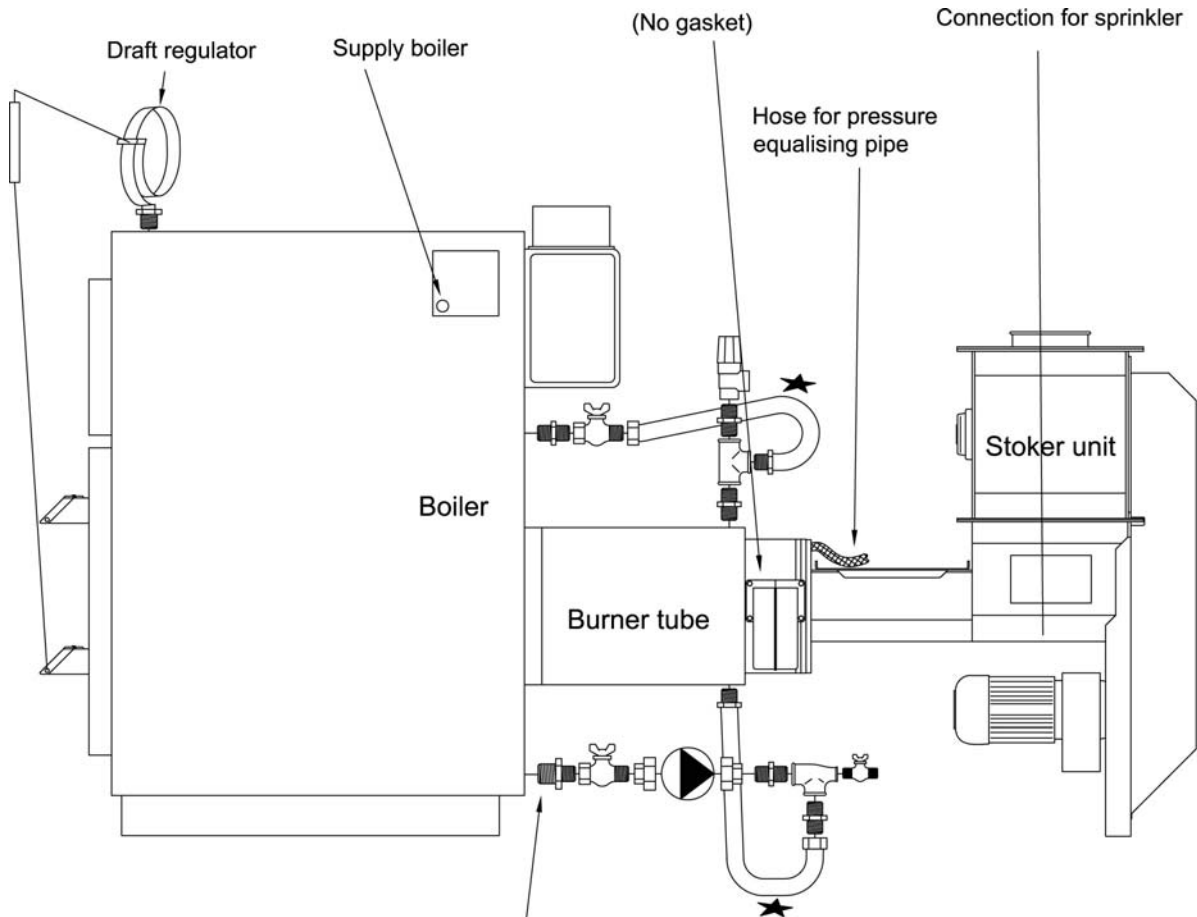

Included fittings

- 2 pcs. 3/4" hose
- 1 pcs. 3/4" safety valve
- 1 pcs. circulation pump
- 2 pcs. 3/4" union joint, for pump
- 2 pcs. 3/4" shutoff valve
- 1 pcs. 1/2" shutoff valve
- 5 pcs. 3/4" hexagon nipple
- 1 pcs. 3/4" tee
- 1 pcs. 3/4" x 3/4" x 1/2" tee
- 1 pcs. 3/4" plug

★ **Elbows and valves are to be placed horizontal, to avoid airpockets in the hoses!**

- ME20: 3/4" x 1" hexagon nipple
- ME40: 3/4" x 1 1/2" hexagon nipple
- ME80: 3/4" x 2" connection nipple + 3/4" hexagon nipple

Diagram 2 – Connection to the heating system

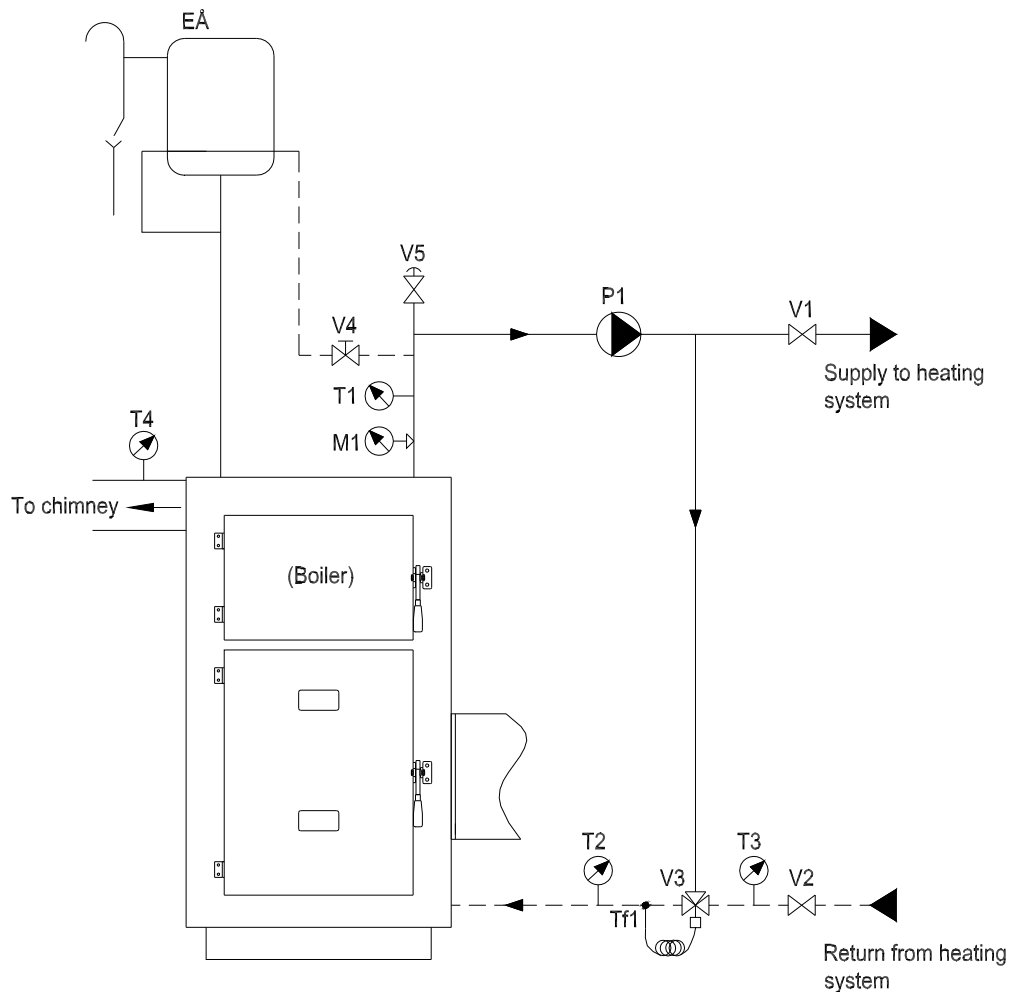

	Open expansion vessel	EÅ	
	shutoff valve	V1-V2	shutoff valves on supply and return, in the boiler room. More can be installed if needed.
	3 way thermostat controlled mixing valve (shunt valve)	V3	Boiler shunt valve secure that the return water to the boiler always is over 60°C.
	Manuel regulation valve (return valve)	V4	To protect open expansion vessel against frost Can be thermostatic return valve
	Airing	V5	Airing, possible automatic, placed where needed.
	Thermometer	T1-T4	Thermometer for supply, water return before and after shunt valve and for flue temperature
	Temperature sensor	TF1	Temperature sensor to regulate shunt valve.
	Manometer	M1	Manometer for boiler pressure.
	Pump	P1	Circulation pump for heating system

Diagram 3 – connection of the external auger

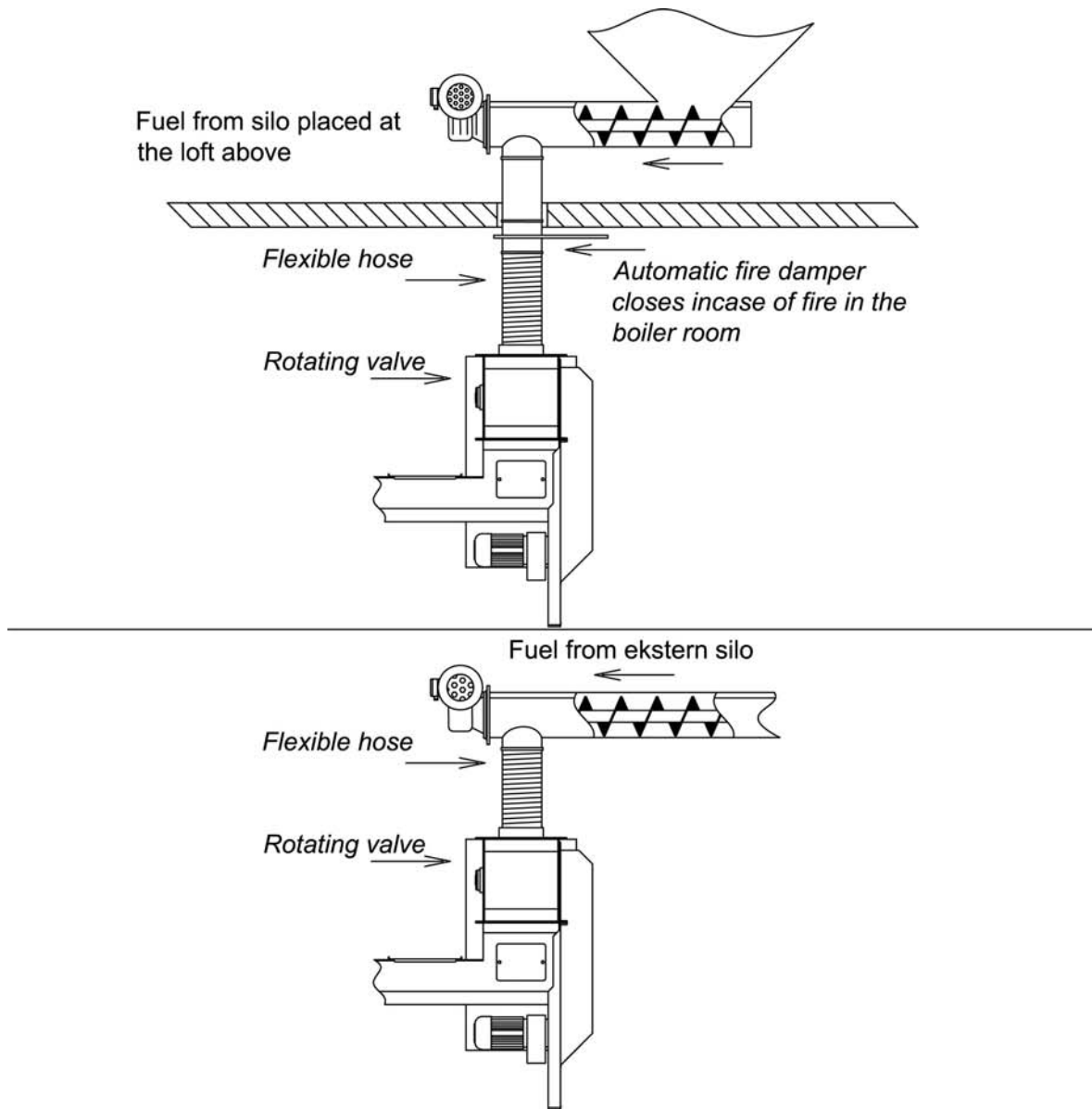

The auger must not support on the stokerunit, and vibrations from the auger must not be transmitted to the stokerunit

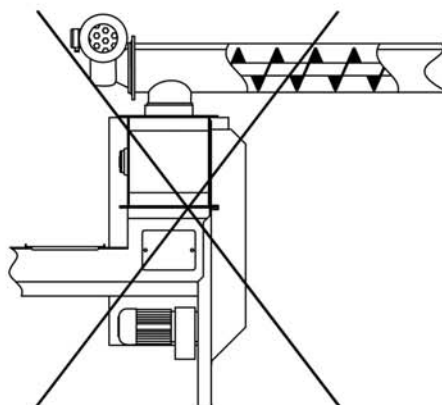

Diagram 4 – Connection to the chimney

*** Prefabricated module chimneys should not be placed on top of the flue outlet, as this allows rainwater or possible condense water to run directly down into the heat exchanger of the boiler, where it will cause corrosion !**

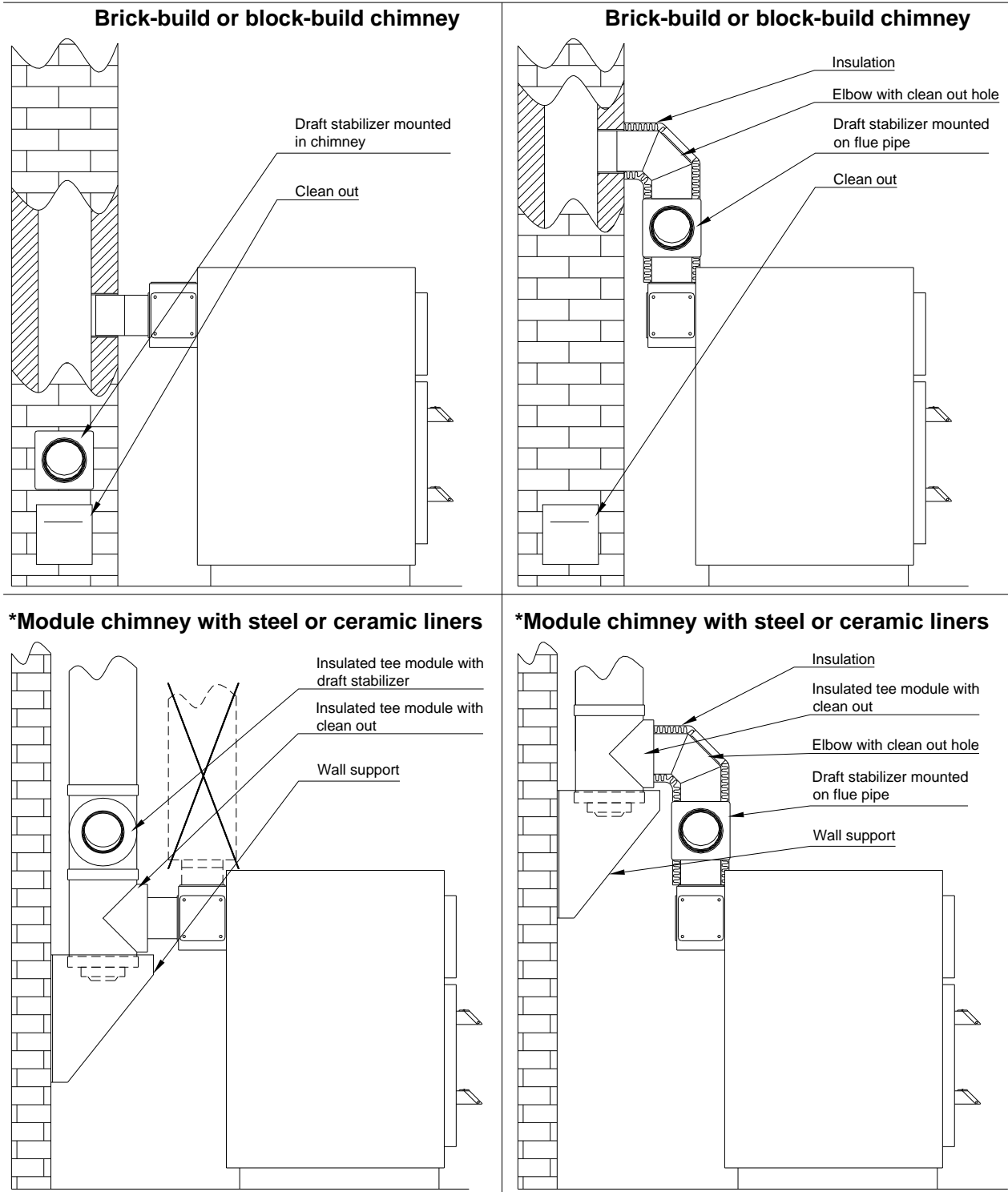
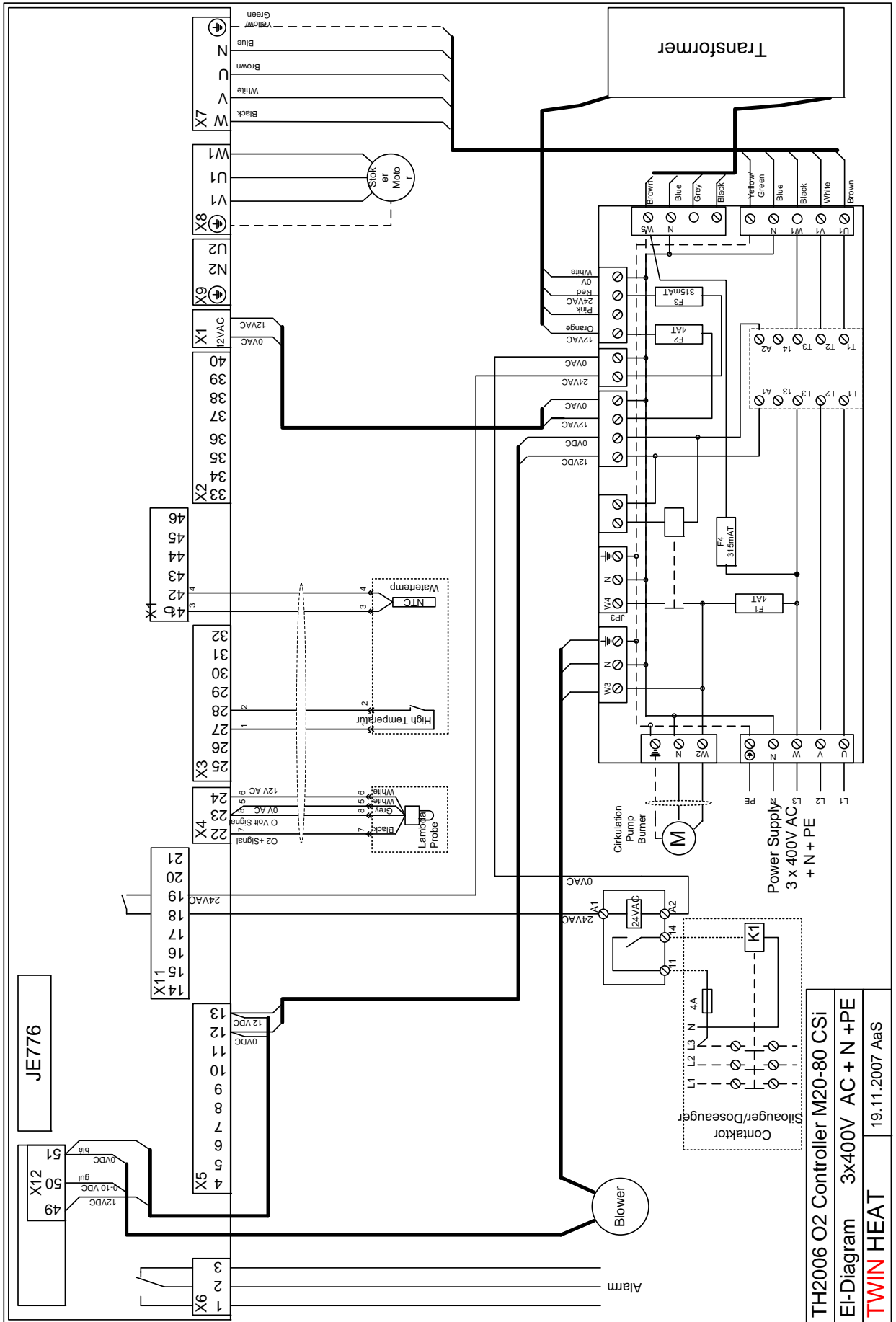

Diagram 5 – Electrical diagram 400V – 3 phase



TH2006 O2 Controller M20-80 CSi
 EI-Diagram 3x400V AC + N + PE
 TWIN HEAT 19.11.2007 AaS

DIAGRAM 5

Diagram 5.1 – Electrical diagram 230V – 1 phase

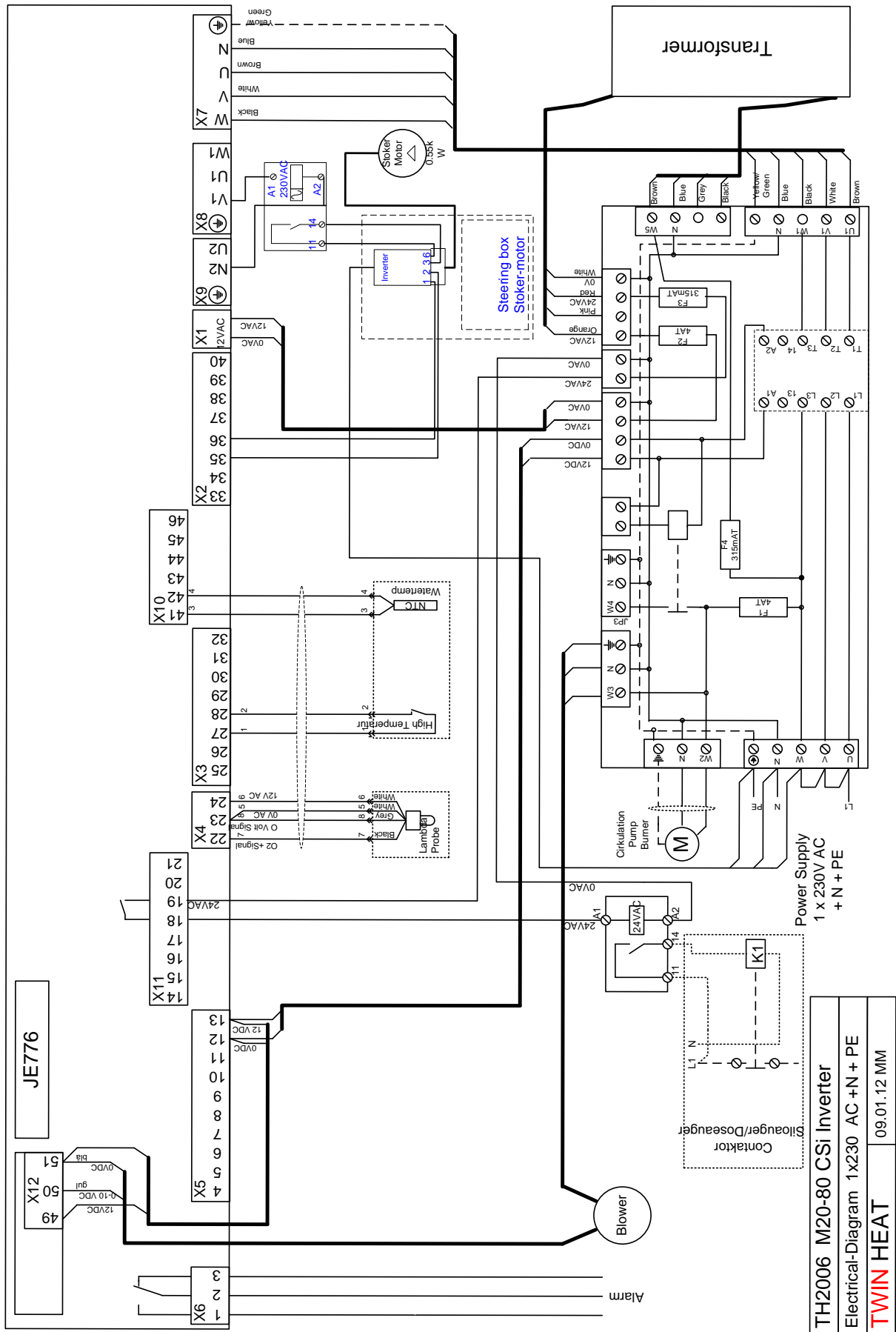

TH2006 M20-80 CSI Inverter	09.01.12 MM
Electrical-Diagram 1x230 AC+N+PE	
TWIN HEAT	

DIAGRAM 5.1